

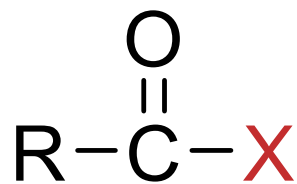

第十二章 羧酸衍生物

羧酸衍生物的分类



酰卤

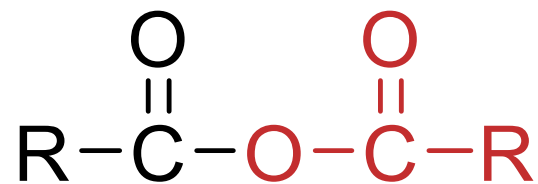

酸酐

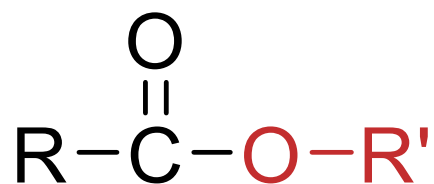

酯

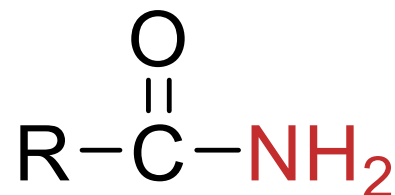

酰胺



腈

酰卤的命名



乙酰氯
acetyl chloride



苯甲酰溴
benzoyl bromide

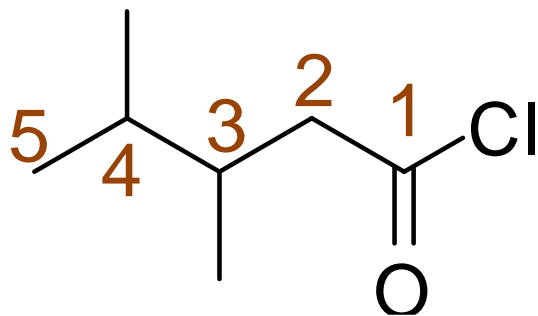

3,4-二甲基戊酰氯
3,4-dimethylpentanoyl
chloride

酸酐的命名

来源羧酸名称 + 酐



乙(酸)酐
acetic anhydride

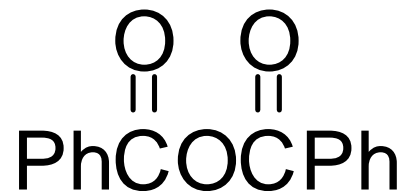

苯甲酸酐
benzoic anhydride

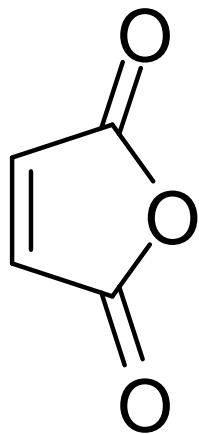

顺丁烯二酸酐
cis-butenedioic
anhydride

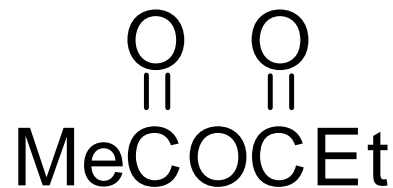

乙丙酐
acetic propionic
anhydride

酯的命名

来源羧酸 + 来源醇/酚名称



苯甲酸苄酯
benzyl benzoate

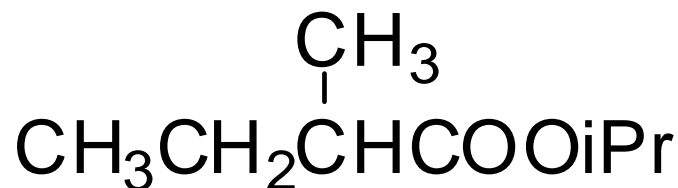

2-甲基丁酸异丙酯
isopropyl 2-methylbutanoate

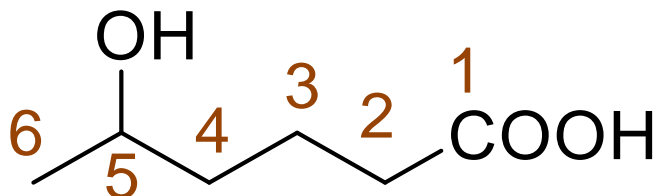

5-羟基己酸
5-hydroxyhexanoic acid

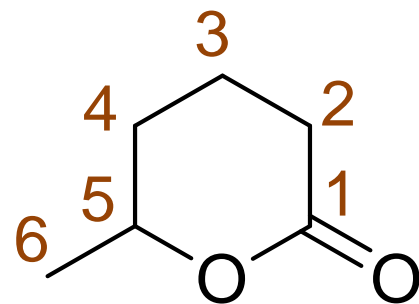
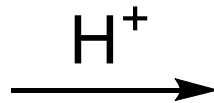

己-5-内酯
hexano-5-lactone

酰胺的命名

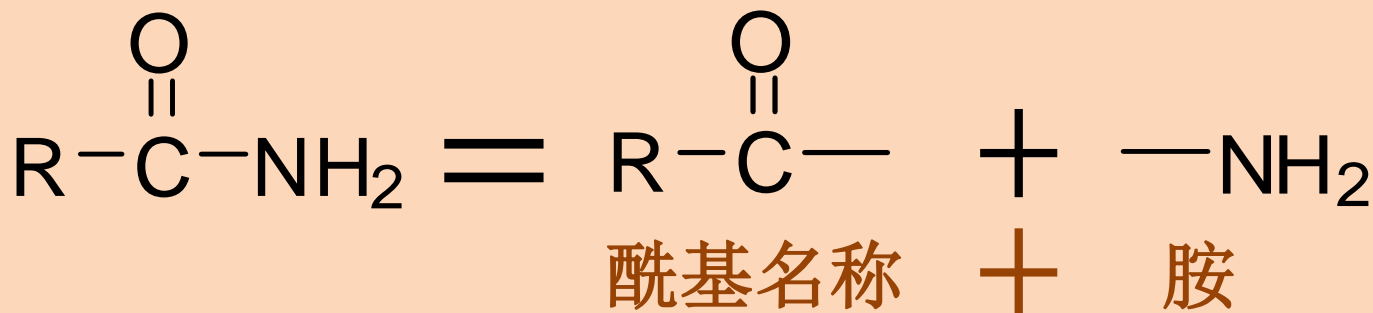

乙酰胺
acetamide

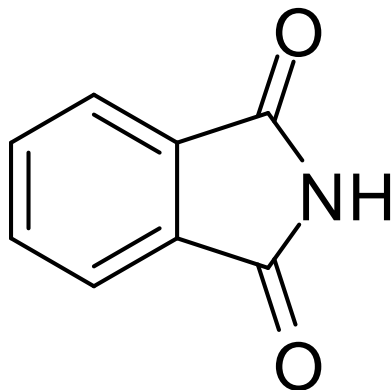
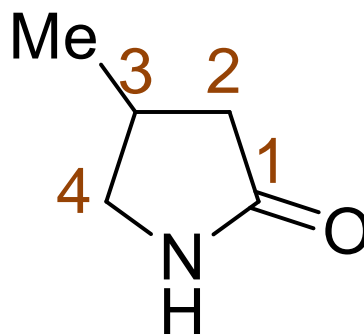

邻苯二甲酰亚胺
benzene
-1,2-dicarboximide

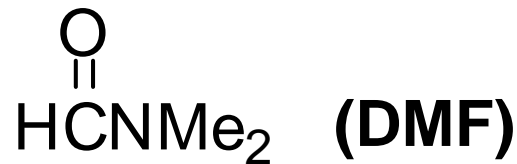

N,N-二甲基甲酰胺
N,N-dimethylformamide

腈的命名

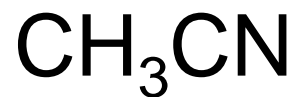

乙腈
acetonitrile

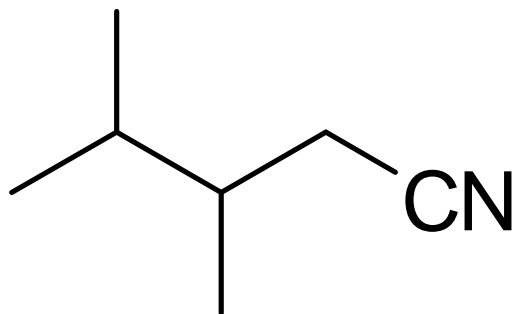

3,4-二甲基戊腈
3,4-dimethylpentanenitrile

命名：特性基团优先级次序

$\text{RCOOH} > \text{RSO}_3\text{H}$

$> (\text{RCO})_2\text{O} > \text{RCOOR} > \text{RCOX} > \text{RCONH}_2 > \text{RCN}$

$> \text{RCHO} > \text{RCOR}$

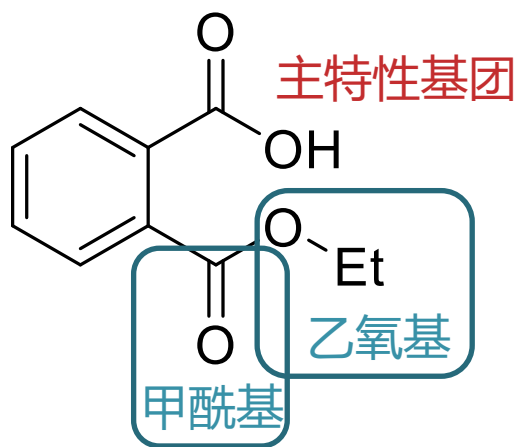

邻乙氧甲酰基苯甲酸

2-(ethoxycarbonyl)benzoic acid

邻苯二甲酸单乙酯

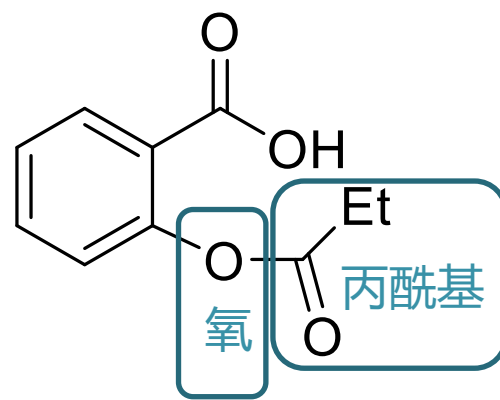

邻丙酰氧基苯甲酸

2-(propionyloxy)benzoic acid

羧酸衍生物的结构

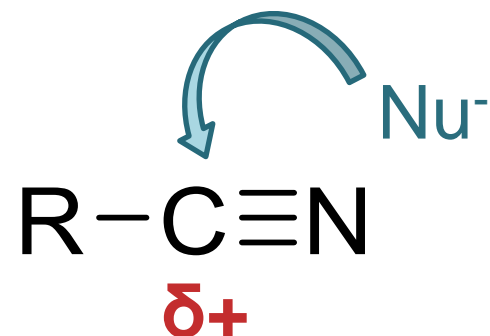
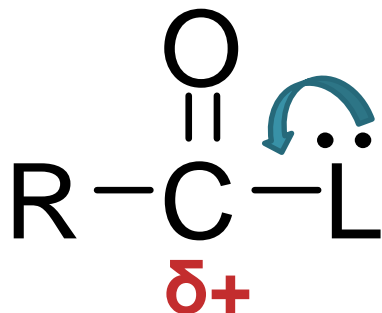

	酰卤	酸酐	酯	酰胺
	-X	-OCOR	-OR	-NH ₂
共轭效应	+C	+C	+C	+C
诱导效应	-I	> -I	> -I	> -I
给电子倾向	-X	< -OCOR	< -OR	< -NH ₂
中心碳正电荷密度/ 亲核反应活性	高	←————→		低

羧酸衍生物与亲核试剂间的反应

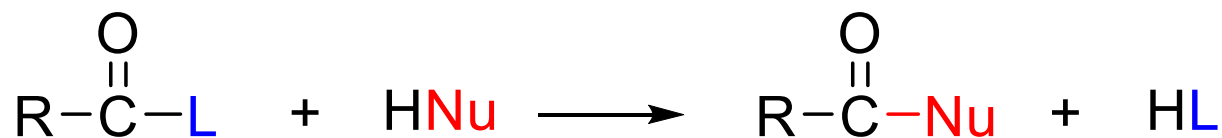
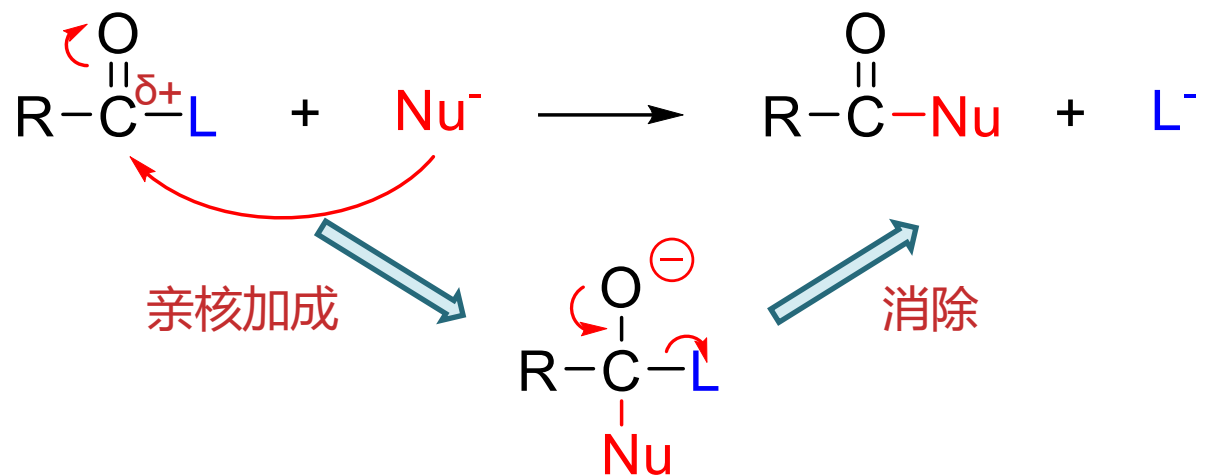

反应活性: $RCOX > (RCO)_2O > RCOOR > RCONH_2$

酰卤的水醇氨解

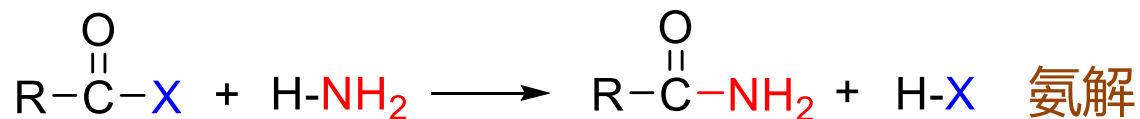
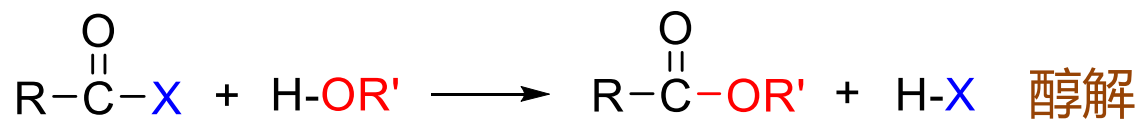
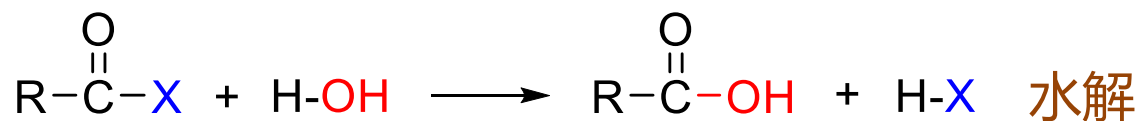

缚酸剂

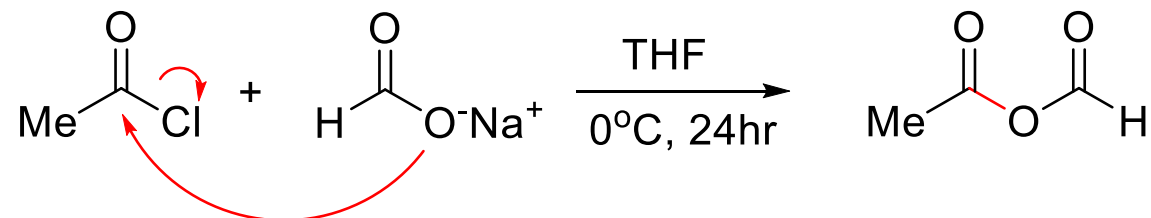
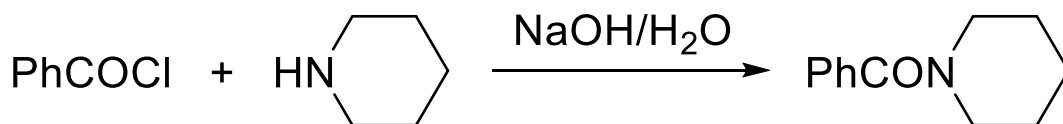
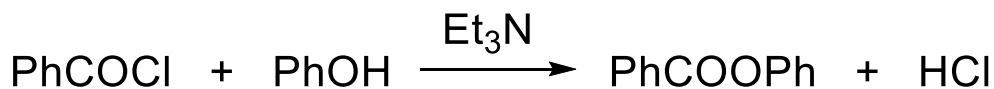

合成中酰卤
是常见的高活性酰化剂

酸酐的水醇氨解

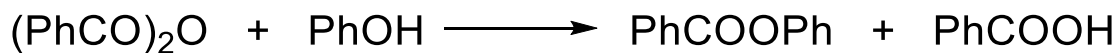
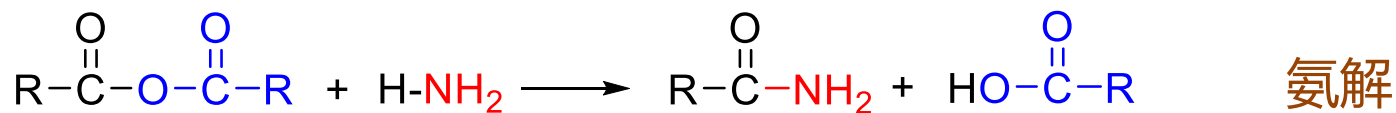
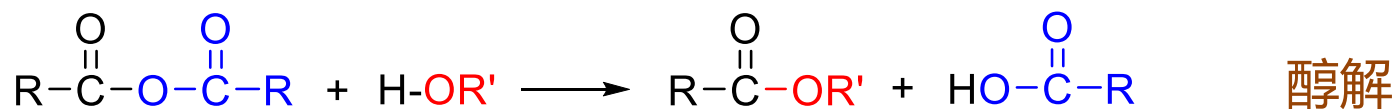
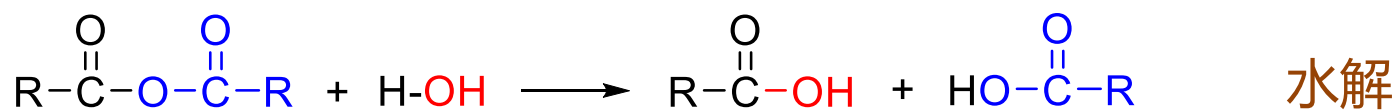

合成中酸酐
是常见的
较高活性酰化剂

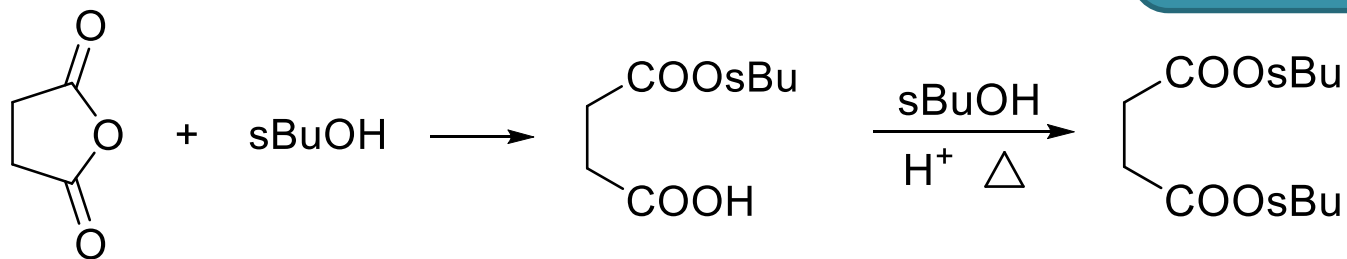

酯的水醇氨解

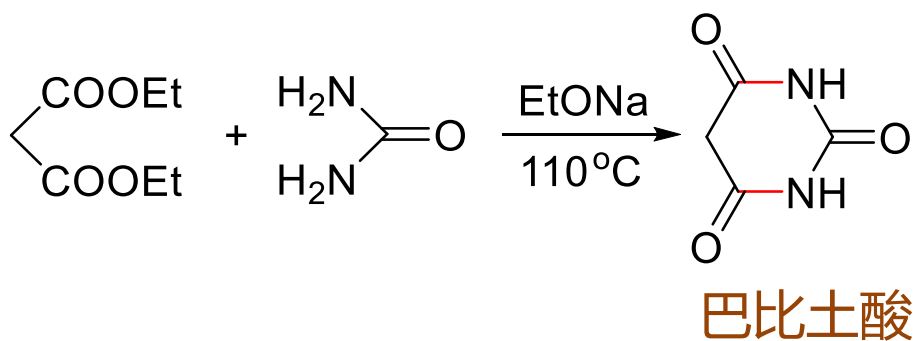
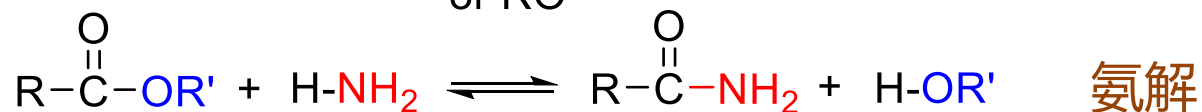
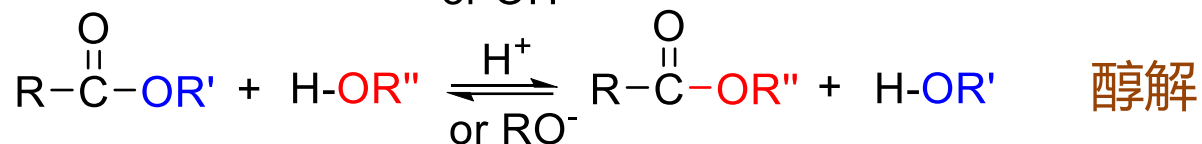
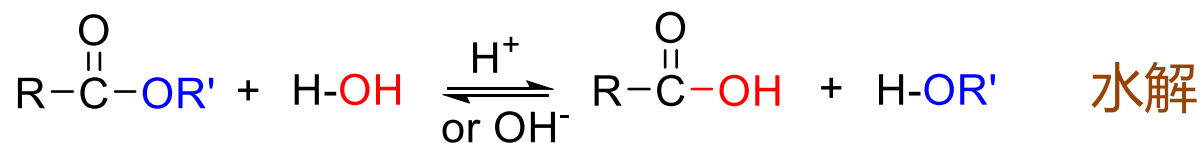

酯的醇解与氨解
常用以合成
特殊结构的酯与酰胺

酯的水醇氨解

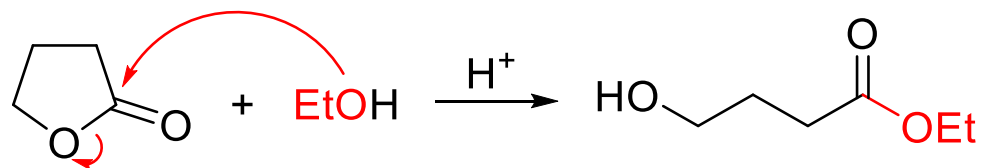
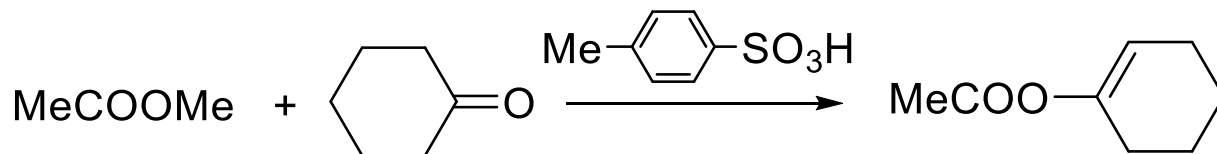
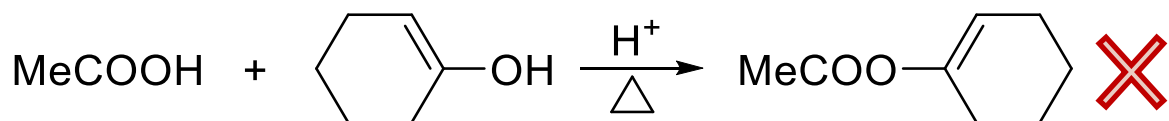
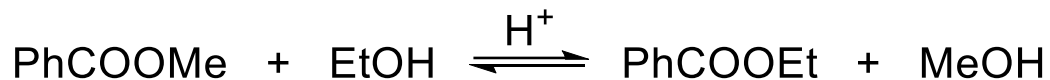
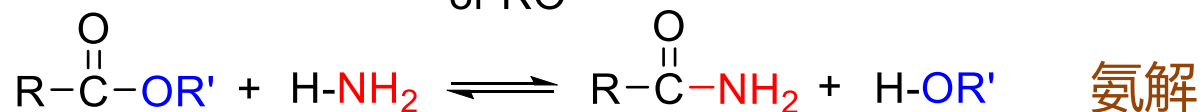
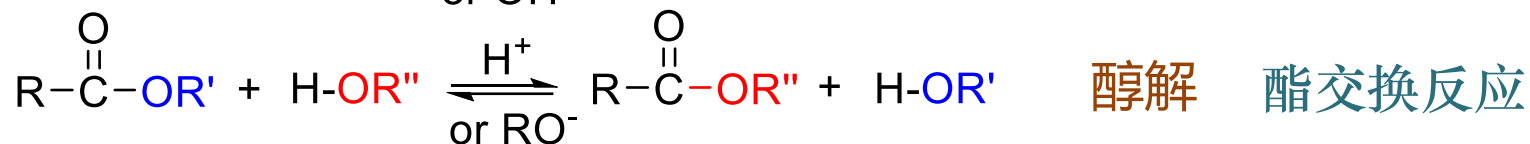
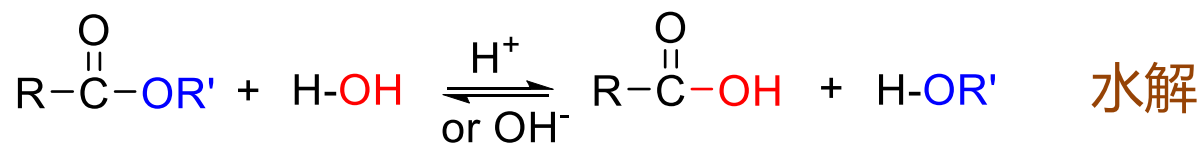

酰胺的水解

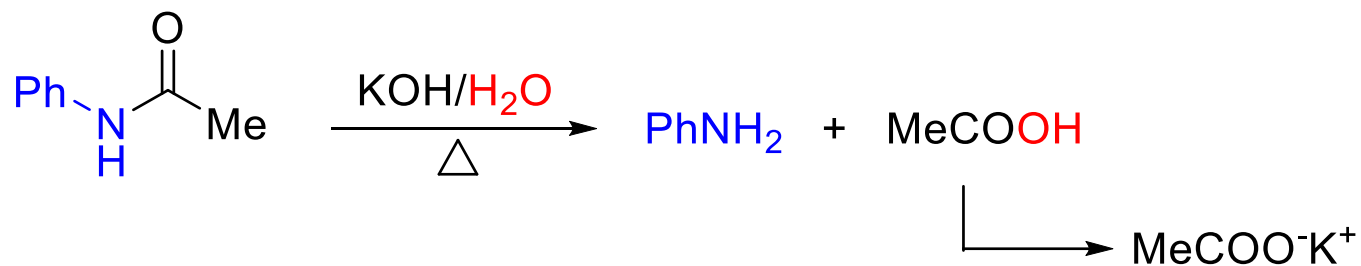
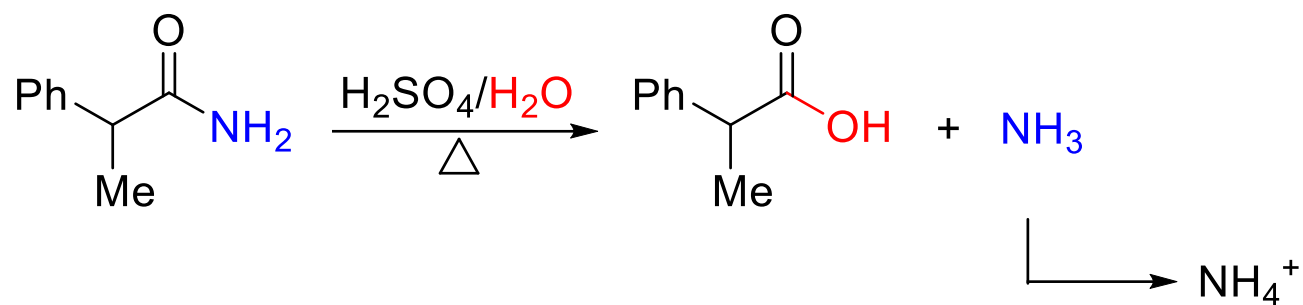

腈的水醇解

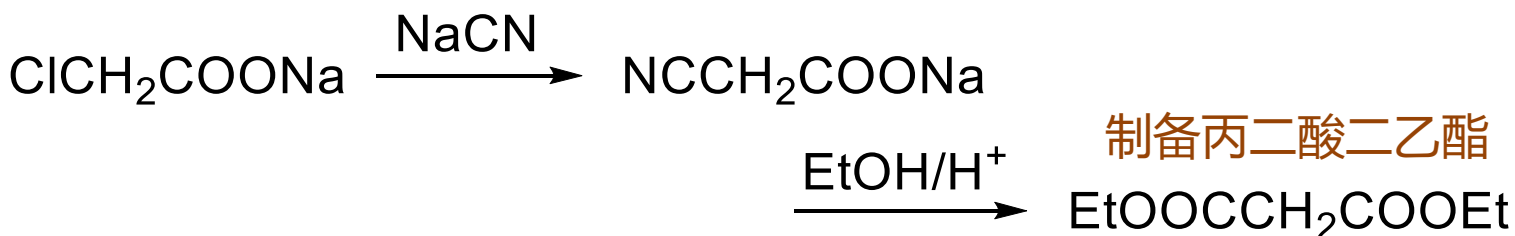
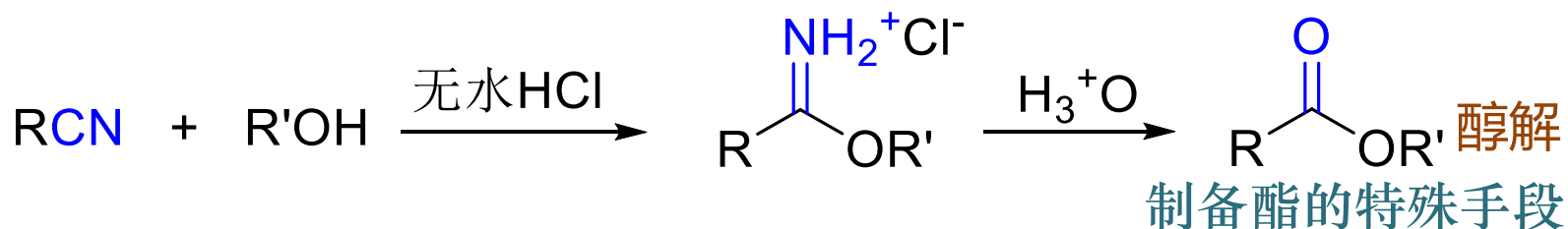
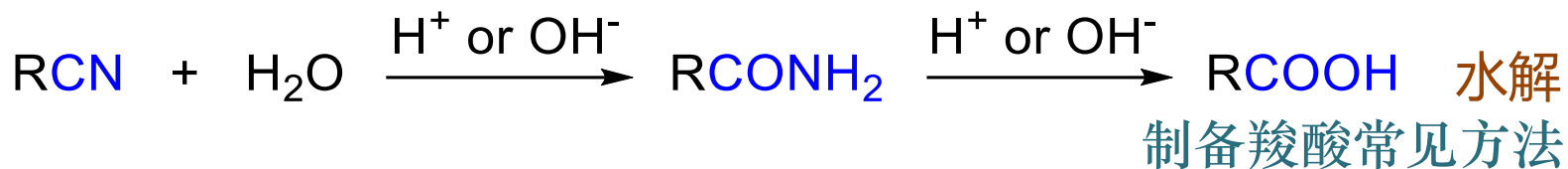

羧酸/羧酸衍生物间的相互转化

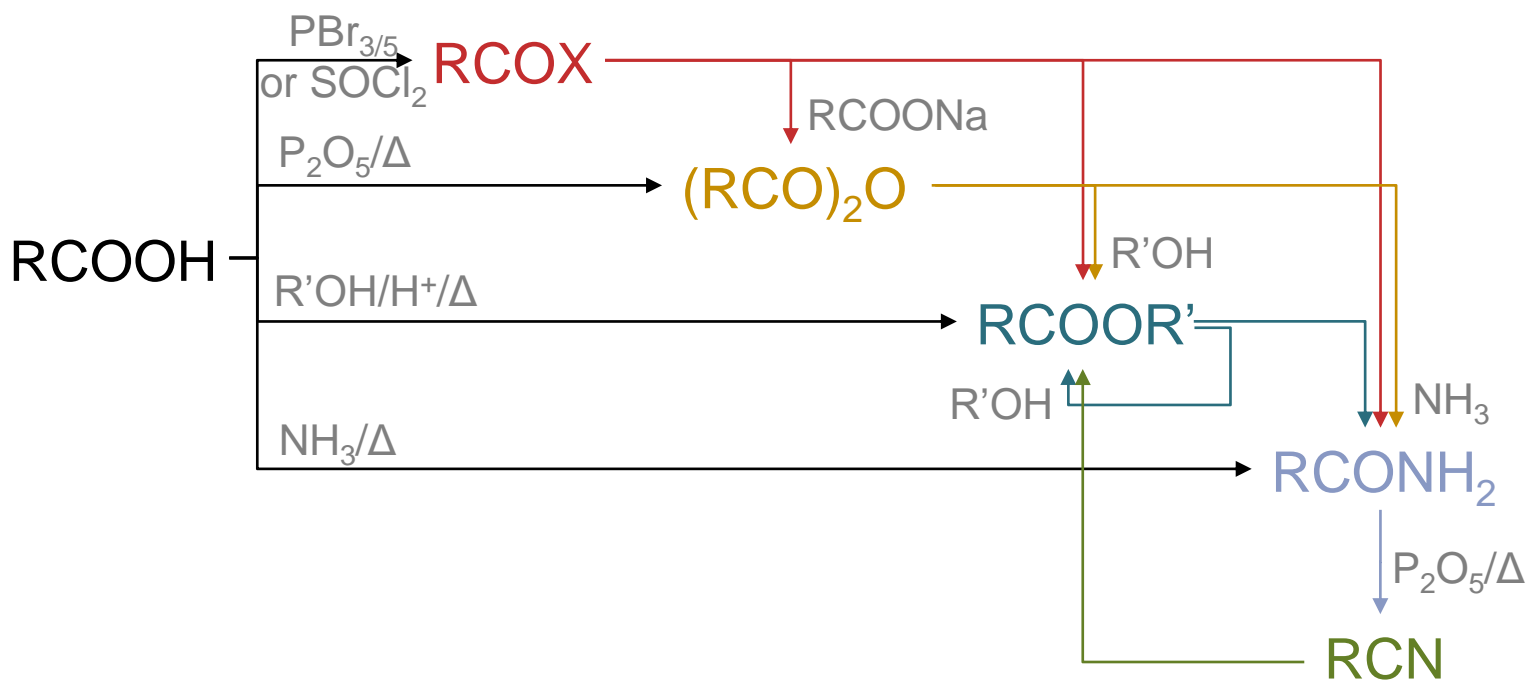

(五种羧酸衍生物水解后均得到羧酸)

酯碱性水解反应历程

- 位阻效应
- 电性效应
- 酰氧断裂

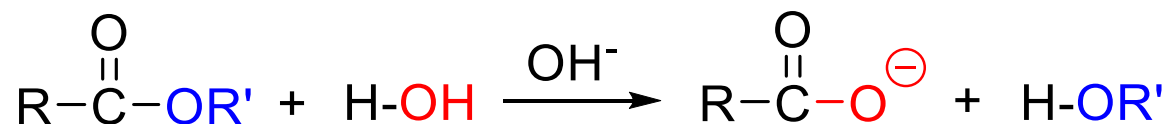

R与R' 位阻愈小对反应愈有利

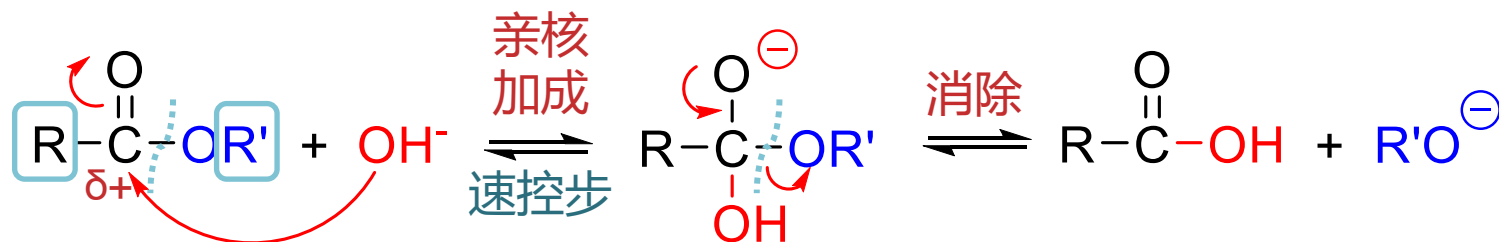

R侧有吸电子基利于反应进行

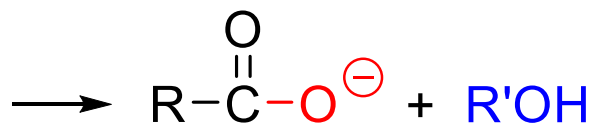

酯碱性水解反应历程特征

- 位阻效应

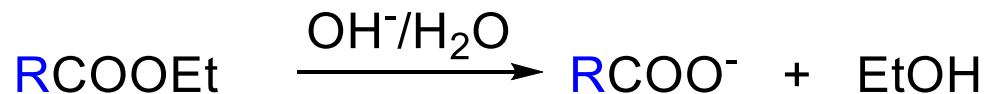
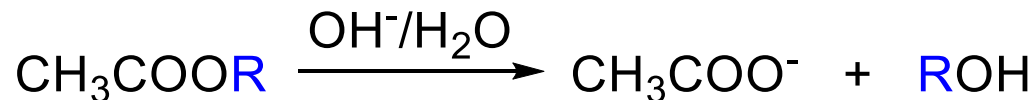

- 电性效应

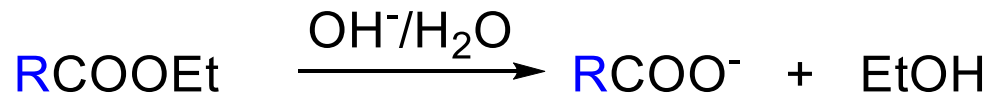

酯碱性水解反应历程特征

- 酰氧断裂

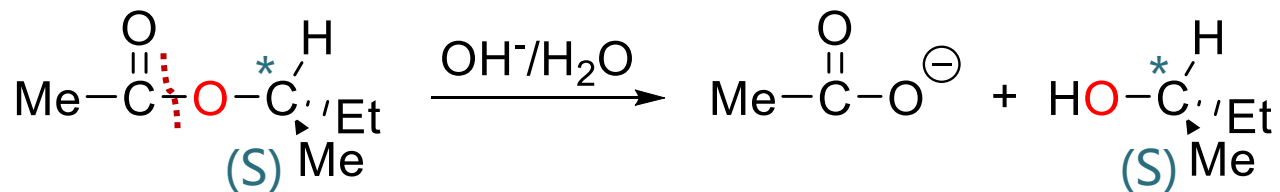
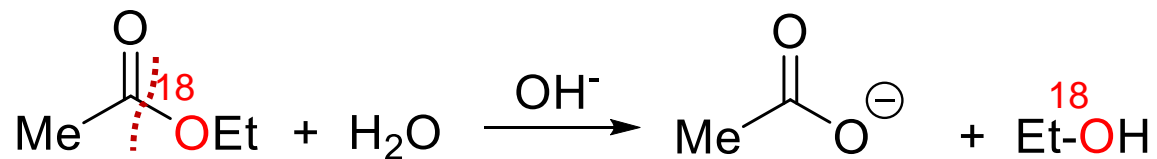

酯酸性水解反应历程1

- 位阻效应
- 电性效应
- 酰氧断裂

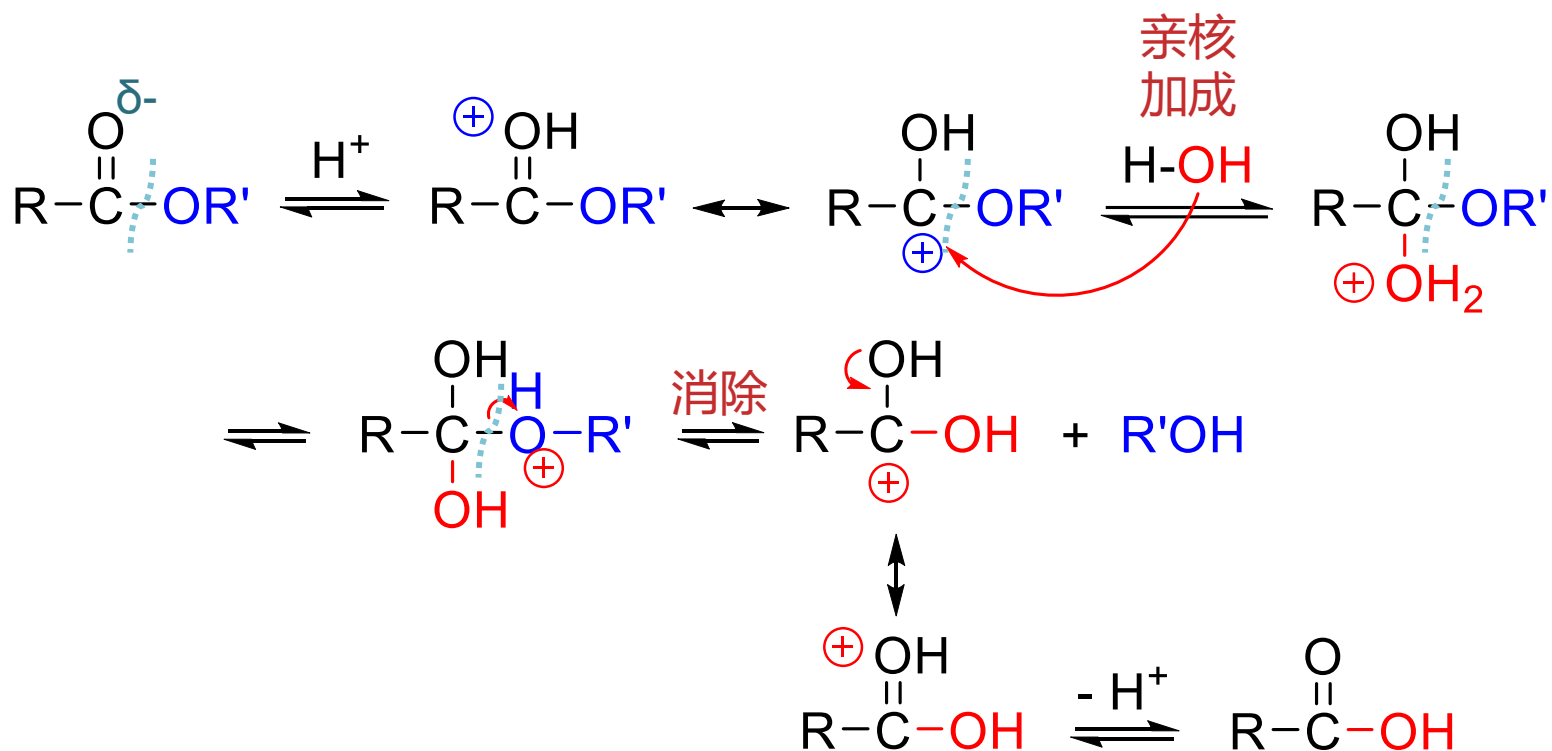
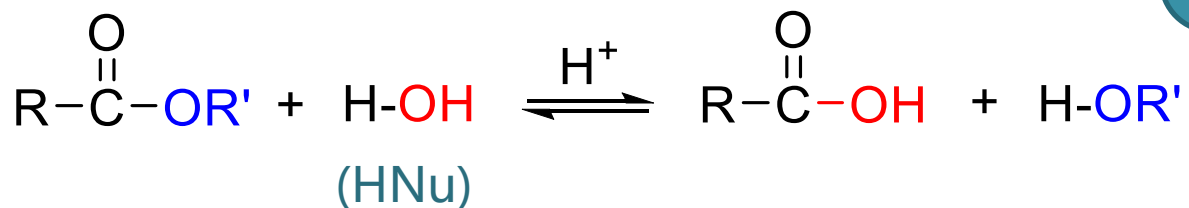

酯酸性水解反应历程2

• 烷氧断裂

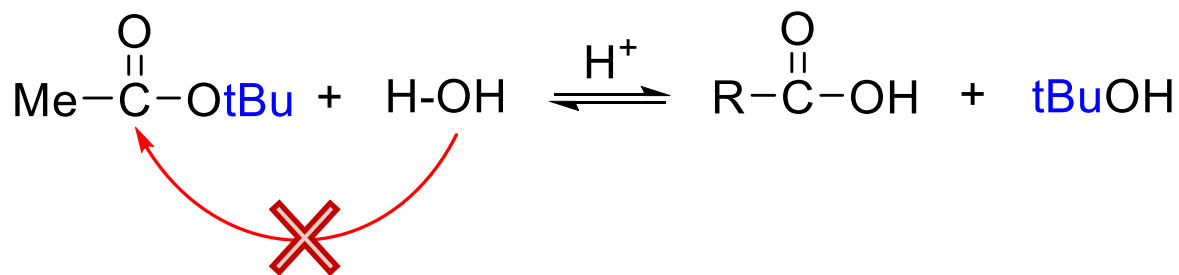

仅在叔醇酯
水解时出现

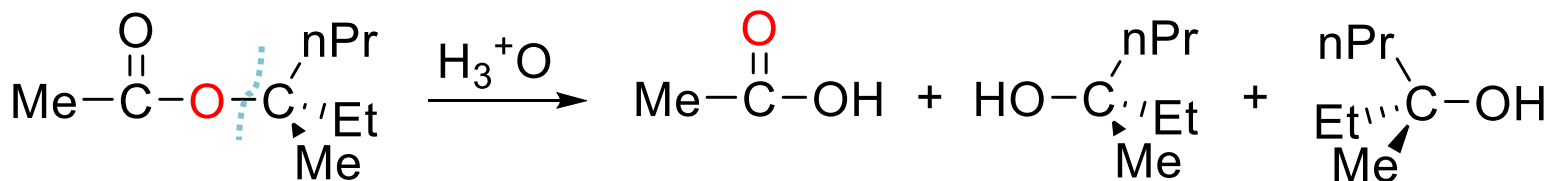
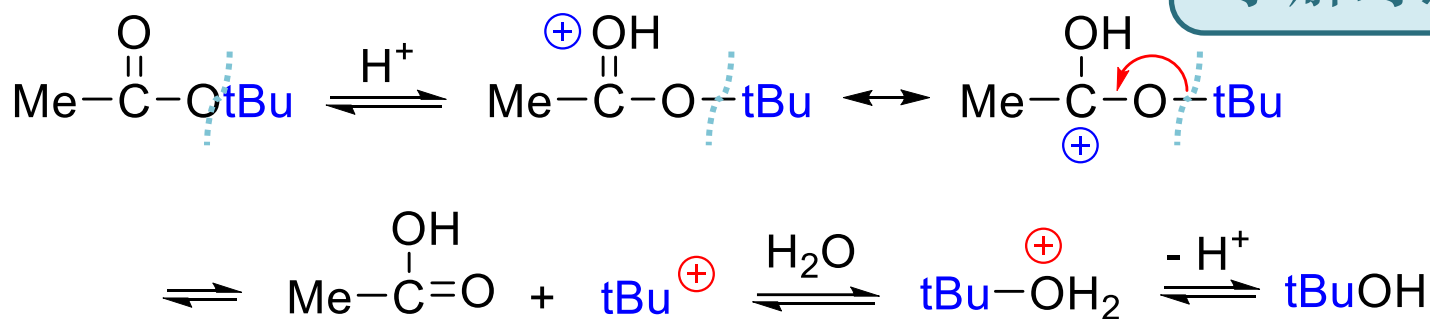

酯水解反应历程

- 碱催化
 - 亲核加成-消除过程
 - 反应不可逆

合成中使用碱催化酯水解较多

- 酸催化
 - 亲核加成-消除过程
 - 碳正离子过程
 - 反应可逆

其它羧酸衍生物的水醇氨解历程亦以亲核加成-消除过程为主

羧酸衍生物与金属有机化合物反应

- 格氏试剂

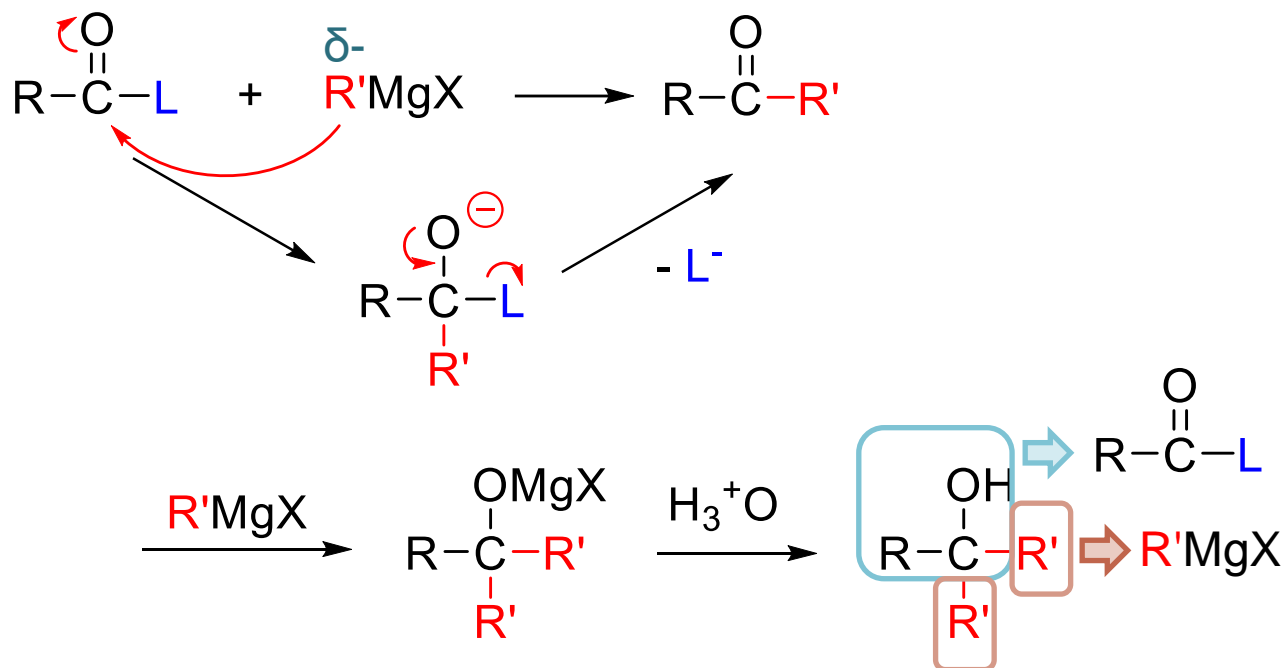

产物特征：
α-C连接两个相同烃基的醇

羧酸衍生物与金属有机化合物反应

- 格氏试剂

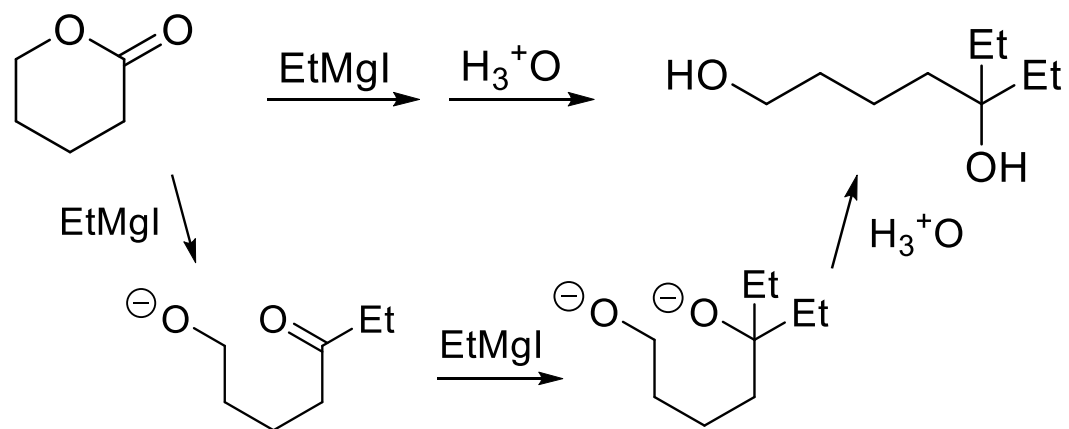
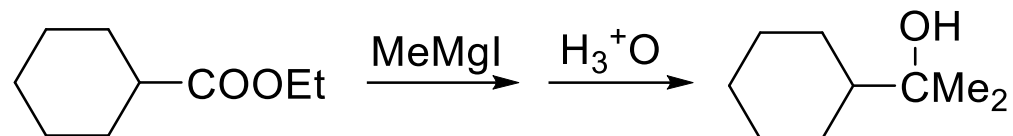

羧酸衍生物与金属有机化合物反应

- 格氏试剂

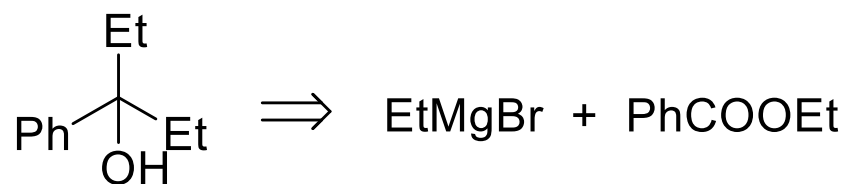
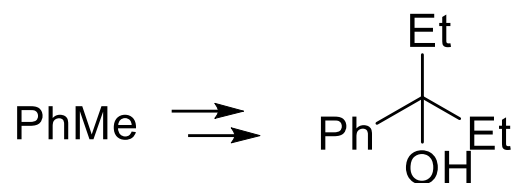

羧酸衍生物与金属有机化合物反应

- 二烷基铜锂

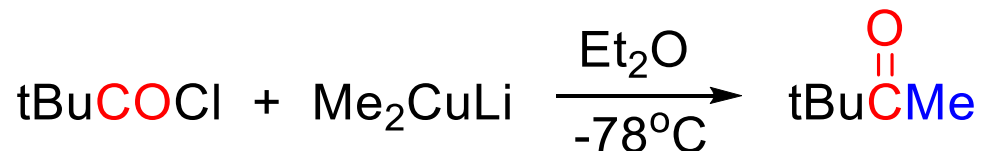
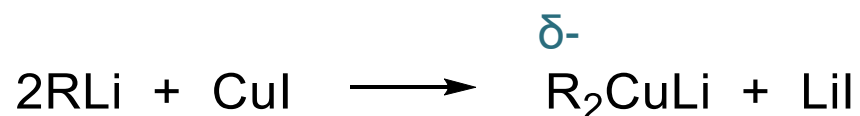

低温下与酰氯的反应可停留在得到羰基化合物一步

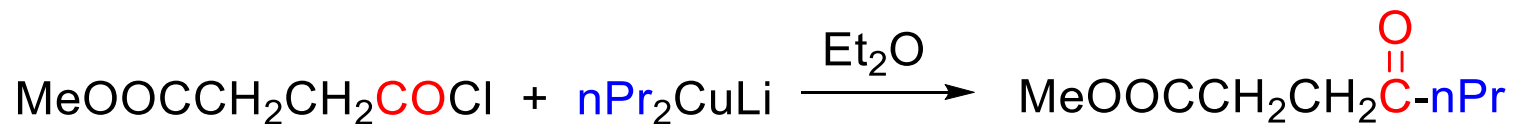

羧酸衍生物的还原

• LiAlH_4

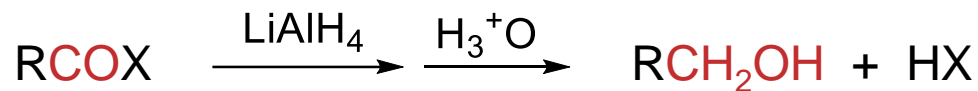
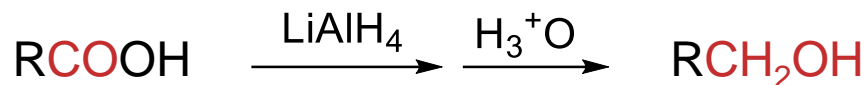

较少使用

常用作将
天然酯转变为醇

合成胺的
常见手段

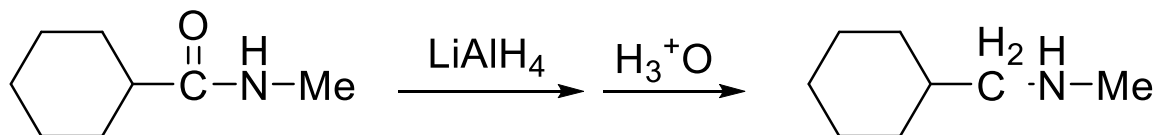
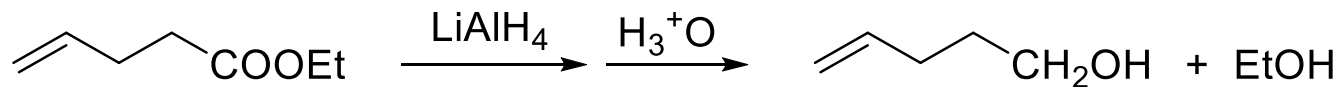

羧酸衍生物的还原

- Bouveault-Blanc反应

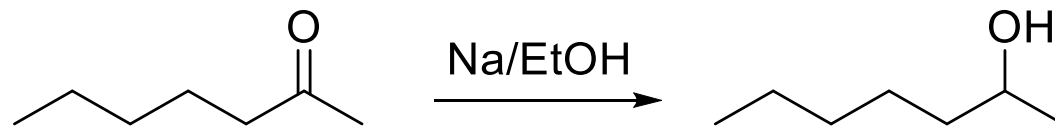
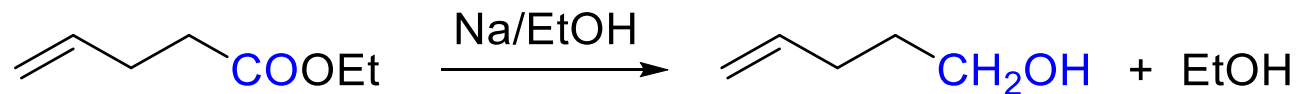

Na/EtOH传统上亦是较普适的还原试剂

羧酸衍生物的还原

- 腈的催化氢化

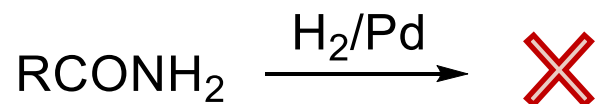
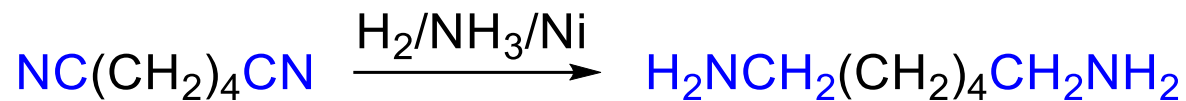

羧酸衍生物的还原

- Rosenmund还原



酰胺的特殊性质

- 酸碱性

胺

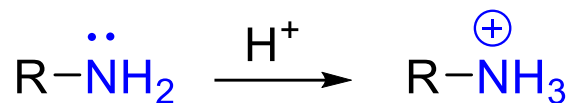

碱性

酰胺

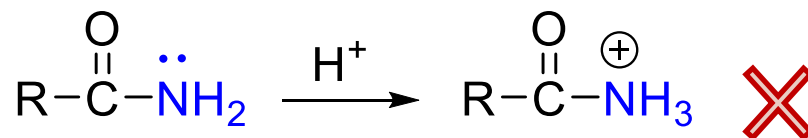

中性

酰亚胺

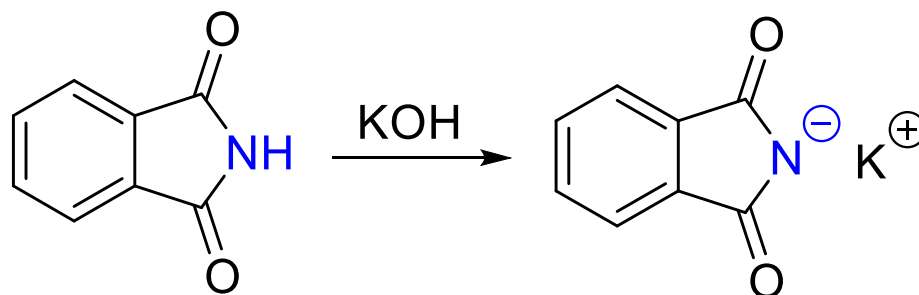

酸性

酰胺的特殊性质

- 酸碱性

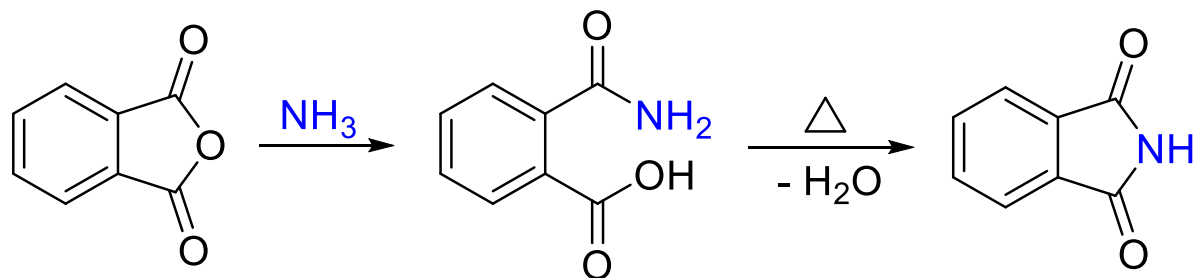

邻苯二甲酰亚胺的制备

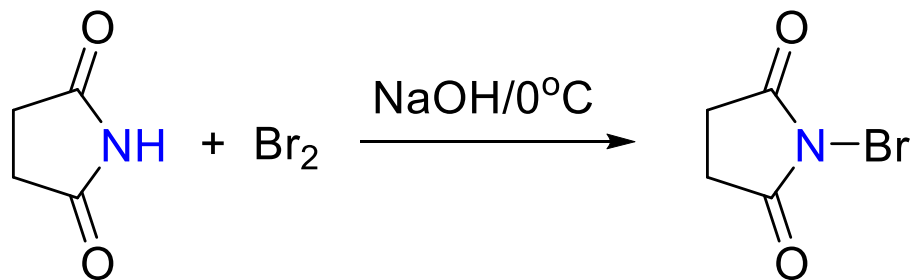

N-溴代丁二酰亚胺 (NBS)

酰胺的特殊性质

- Hofmann降解

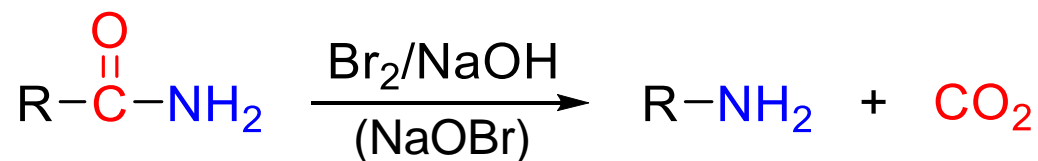

一般需N上连接双氢时才可发生

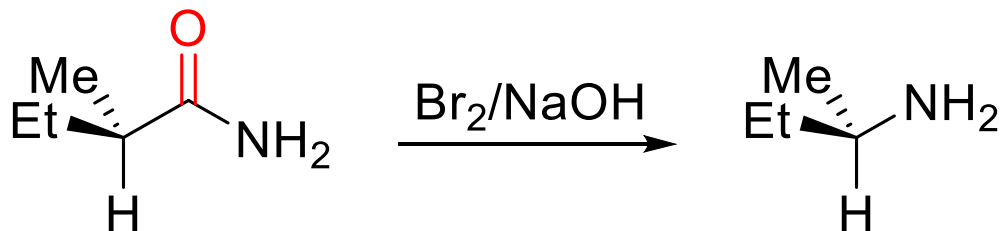
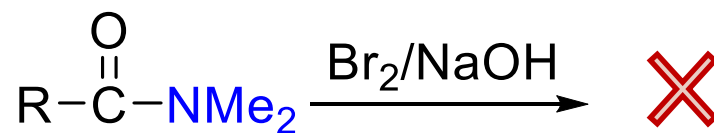

立体选择性极高

碳酸衍生物

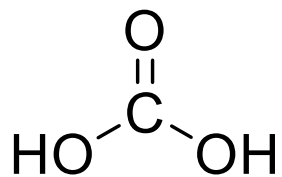

碳酸

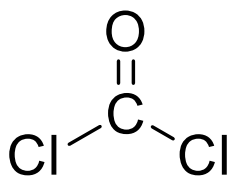

碳酰氯 (光气)

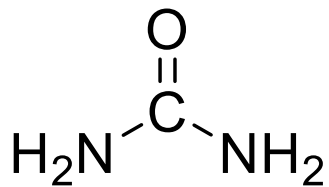

碳酰胺 (脲)

碳酸衍生物的反应

- 碳酰氯

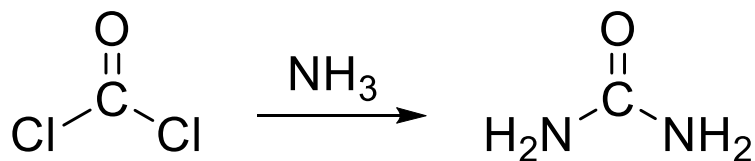
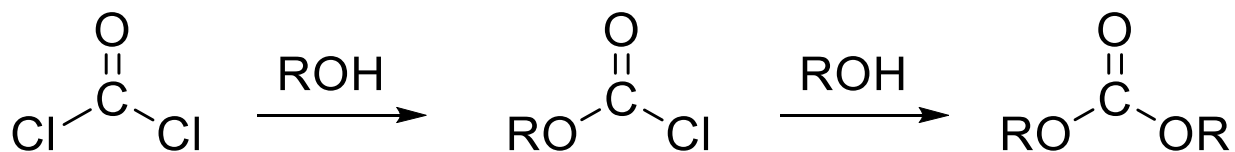
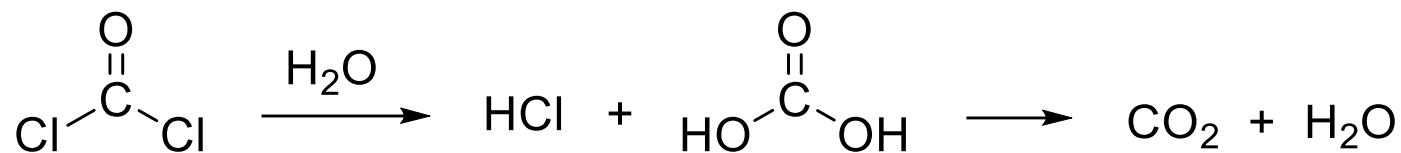

碳酸衍生物的反应

- 碳酰胺

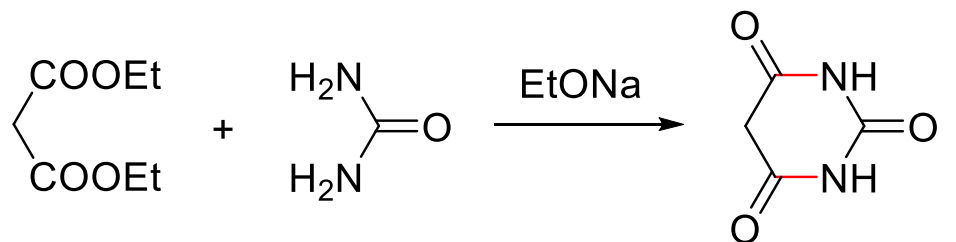

巴比土酸

碳酰胺部分具备胺的性质

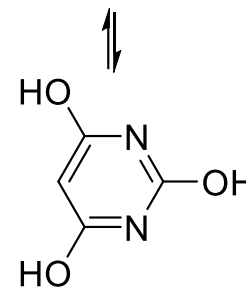

碳酸衍生物

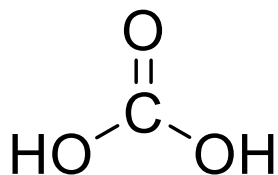

碳酸

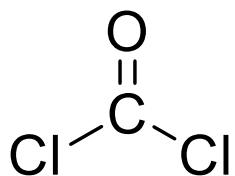

碳酰氯 (光气)

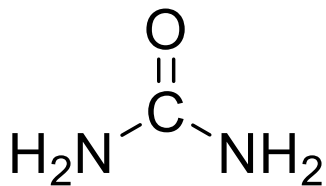

碳酰胺 (脲)

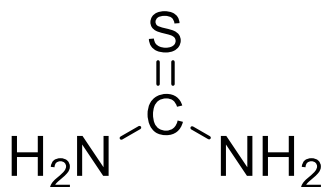

硫脲

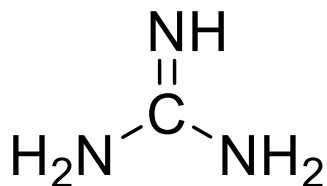

亚氨基脲 (胍)

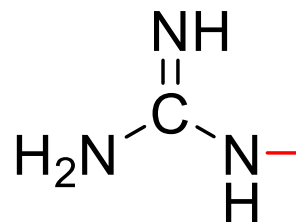

胍基

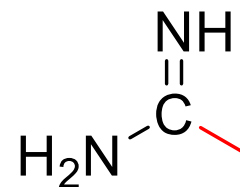

脒基

胍及其衍生基团碱性与KOH相当